



P24CM02H

I²C-Compatible Serial E²PROM

Datasheet Rev.0.5

General Description

The P24CM02H is I²C-compatible Serial EEPROM (Electrically Erasable Programmable Memory) device. It contains a memory array of 2048 Kbits (256 Kbytes), which is organized in 256 bytes per page.

Features

- Single Supply Voltage and Support Fast and High Speed Mode
 - ◇ Minimum operating voltage down to 1.7 V
 - ◇ 400 kHz/1 MHz clock from 1.7 V to 5.5 V
 - ◇ 3.4 MHz clock from 1.7 V to 5.5 V
- Low power CMOS technology
- Schmitt Trigger, Filtered Inputs for Noise Suppression
- Transparent ECC on each group of four bytes which can correct 1 bit error
- Write protect of the whole memory array
- Additional write lockable page (Identification page)
- Additional 128 bits Serial Number (Unique ID)
- Sequential & Random Read Features
- 256 bytes Page Write Modes, Partial Page Writes Allowed
- Self-timed Write Cycle (5 ms maximum)
- High Reliability
 - ◇ Endurance: 10 Million Write Cycles
 - ◇ Data Retention: 200 Years
 - ◇ HBM: 6 kV
 - ◇ Latch up Capability: +/- 200mA(25C)
- Package: PDIP8, SOP8, TSSOP8, MSOP8, UDFN8, SOT23-5, TSOT23-5

1. Pin Configuration

1.1 Pin Configuration

Figure 1-1 Pin Configuration

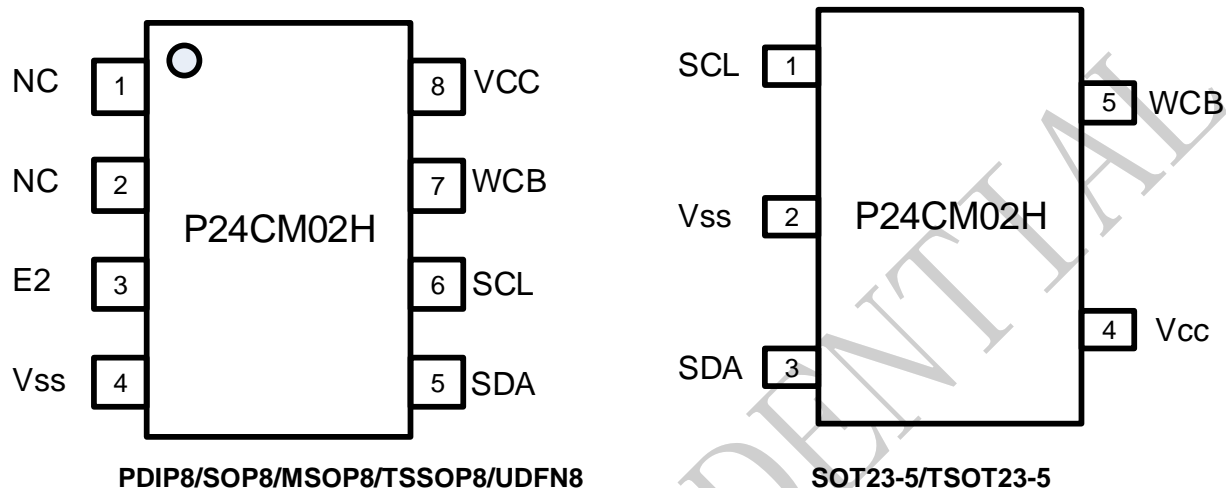

1.2 Pin Definition

Table 1-1 Pin Definition for PDIP8/SOP8/MSOP8/TSSOP8/UDFN8 Packages

Pin	Name	Type	Description
1	NC	\	No Connect
2	NC	\	No Connect
3	E2	Input	Slave Address Setting
4	Vss	Ground	Ground
5	SDA	I/O	Serial Data Input and Serial Data Output
6	SCL	Input	Serial Clock Input
7	WCB	Input	Write Control, Low Enable Write
8	Vcc	Power	Power

Table 1-2 Pin Definition for SOT23-5/TSOT23-5 Packages

Pin	Name	Type	Description
1	SCL	Input	Serial Clock Input
2	Vss	Ground	Ground
3	SDA	I/O	Serial Data Input and Serial Data Output
4	Vcc	Power	Power
5	WCB	Input	Write Control, Low Enable Write

1.3 Pin Descriptions

Serial Clock (SCL): The SCL input is used to positive-edge clock data in and negative-edge clock data out of each device.

Serial Data (SDA): The SDA pin is bidirectional for serial data transfer. This pin is open drain driven and may be wire-OR'ed with any number of other open-drain or open-collector devices.

Device Addresses (E2): The E2 pin is device address input. Typically, the E2 pin is for hardware addressing and a total of 2 devices can be connected on a single bus system. If this pin is left floating, the E2 pin will be internally pulled down to Vss.

Write Control (WCB): The Write Control input, when WCB is connected directly to V_{cc}, all write operations to the memory are inhibited. When connected to Vss, allows normal write operations. If the pin is left floating, the WCB pin will be internally pulled down to Vss.

Supply Voltage (V_{cc}): V_{cc} is the supply voltage.

Ground (V_{ss}): Vss is the reference for the V_{cc} supply voltage.

PUYA

CONFIDENTIAL

2. Block Diagram

Figure 2-1 Block Diagram

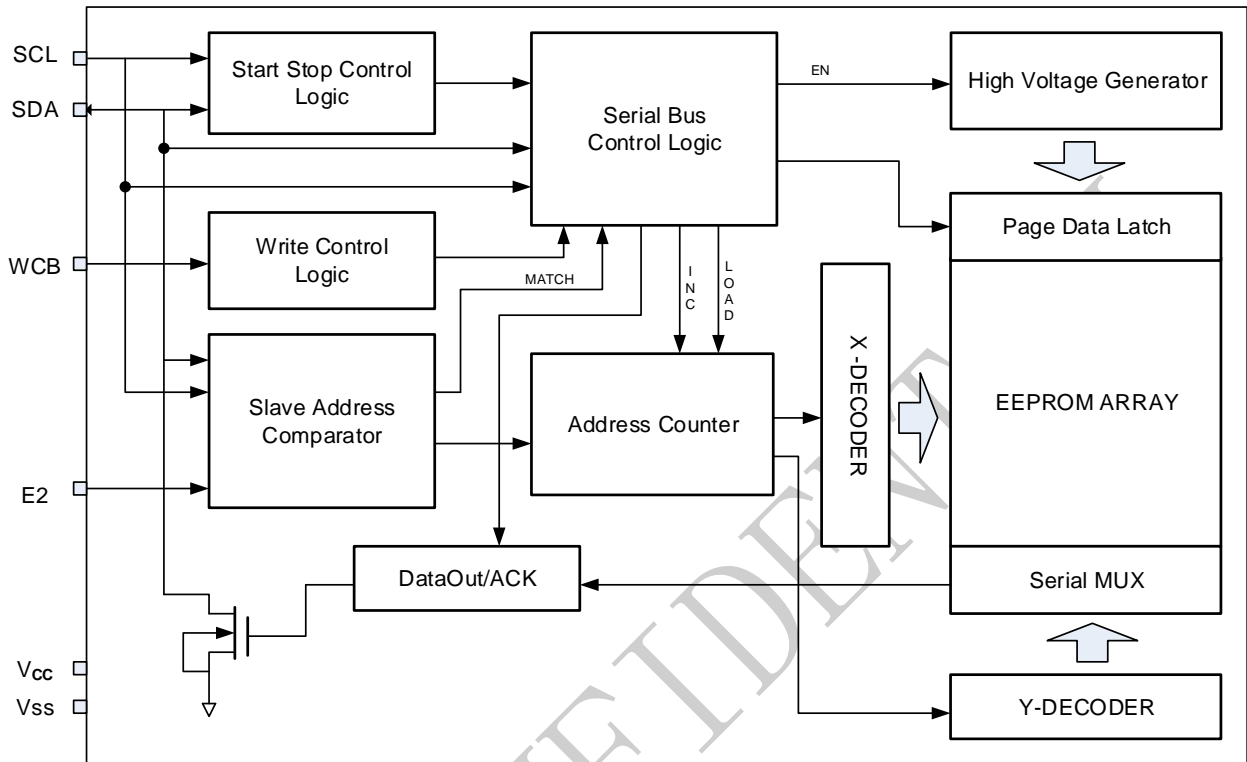

PUYA CONFIDENTIAL

3. Electrical Characteristics

Table 3-1 Absolute Maximum Ratings ^[1]

Symbol	Parameter	Min.	Max.	Units
T _{STG}	Storage Temperature	-65	150	°C
T _A	Ambient operating temperature	-40	125	°C
V _{CC}	Supply Voltage	-0.5	6.5	V
V _{IO}	Input or output range	-0.5	6.5	V
I _{OL}	DC output current (SDA=0)	-	5	mA

Note: [1] Stresses above those listed under "Absolute Maximum Ratings" may cause permanent damage to the device. This is a stress rating only and functional operation of the device at those or any other conditions above those indicated in the operational listings of this specification is not implied. Exposure to maximum rating conditions for extended periods may affect device reliability.

Table 3-2 Pin Capacitance ^[1]

Symbol	Parameter	Max.	Units	Test Condition
C _{I/O}	Input/output Capacitance (SDA)	8	pF	V _{I/O} = V _{SS}
C _{IN}	Input Capacitance (SCL)	6	pF	V _{IN} = V _{SS}

Note: [1] Test Conditions: T_A = 25°C, f_{SCL} = 1MHz, V_{CC} = 3.3V.

Table 3-3 DC Characteristics (Unless otherwise specified, V_{CC} = 1.7 V to 5.5 V, T_A = -40°C to +125°C)

Symbol	Parameter	Min.	Typ.	Max.	Unit	Test Condition
V _{CC}	Supply Voltage	1.7	-	5.5	V	T _A = -40 °C to 125 °C
I _{sb}	Standby Current (Standby mode)	-	1.0 ^[2]	30.0	μA	V _{CC} = 5.5 V, V _{IN} = V _{SS} or V _{CC} , T _A = 85°C
		-	35.0	60.0	μA	V _{CC} = 5.5 V, V _{IN} = V _{SS} or V _{CC} , T _A = 125°C
I _{CC1}	Supply Current (Read)	-	1.2	4.0	mA	V _{CC} = 2.5 V, f _{SCL} = 400 kHz
		-	1.5	4.5	mA	V _{CC} = 5.5 V, f _{SCL} = 400 kHz
		-	1.8	5.0	mA	V _{CC} = 5.5 V, f _{SCL} = 1 MHz
		-	3.0	8.0	mA	V _{CC} = 5.5 V, f _{SCL} = 3.4 MHz
I _{CC2} ^[1]	Supply Current (Write)	-	16.0 ^[3]	20.0	mA	During t _{WR} , 1.7V < V _{CC} < 5.5 V
I _{LI}	Input Leakage Current	-2.0	-	+2.0	μA	V _{IN} = V _{CC} or V _{SS} , device in standby mode
I _{LO}	Output Leakage Current	-2.0	-	+2.0	μA	SDA in Hi-Z, external voltage applied on SDA: V _{SS} or V _{CC}
V _{IL}	Input Low Voltage	-0.45	-	0.3V _{CC}	V	SCL, SDA
V _{IH}	Input High Voltage	0.7V _{CC}	-	V _{CC} +0.5	V	SCL, SDA
V _{OL}	Output Low Voltage	-	-	0.4	V	I _{OL} = 2.1 mA, V _{CC} = 2.5 V

Note: [1] Characterized values, not tested in production

[2] Typ. I_{SB} @ V_{CC} = 5.5V, T_A = 25°C

[3] Typ. I_{CC2} @ V_{CC} = 2.5V

Table 3-4 Fast Mode AC Characteristics ($T_A = -40\text{ }^\circ\text{C}$ to $+125\text{ }^\circ\text{C}$)

Symbol	Parameter	$1.7 \leq V_{CC} \leq 5.5$			$1.7 \leq V_{CC} \leq 5.5$			Units
		Min.	Typ.	Max.	Min.	Typ.	Max.	
f _{SCL}	Clock Frequency	-	-	400	-	-	1000	kHz
t _{LOW}	Clock Pulse Width Low	1.3	-	-	0.55	-	-	μs
t _{HIGH}	Clock Pulse Width High	0.6	-	-	0.3	-	-	μs
t _{AA}	Clock Low to Data Out Valid	0.05	-	0.9	0.05	-	0.50	μs
t _i	Noise Suppression Time	-	-	0.05	-	-	0.05	μs
t _{BUF}	Time the bus must be free before a new transmission can start	1.3	-	-	0.5	-	-	μs
t _{HD.STA}	Start Hold Time	0.6	-	-	0.25	-	-	μs
t _{SU.STA}	Start Setup Time	0.6	-	-	0.25	-	-	μs
t _{HD.DAT}	Data in Hold Time	0	-	-	0	-	-	μs
t _{SU.DAT}	Data in Setup Time	0.1	-	-	0.08	-	-	μs
t _R	Inputs Rise Time ^[1]	-	-	0.3	-	-	0.3	μs
t _F	Inputs Fall Time ^[1]	-	-	0.3	-	-	0.3	μs
t _{SU.STO}	Stop Setup Time	0.6	-	-	0.25	-	-	μs
t _{DH}	Data Out Hold Time	0.05	-	-	0.05	-	-	μs
t _{SU.WCB}	WCB pin Setup Time	1.0	-	-	0.6	-	-	μs
t _{HD.WCB}	WCB pin Hold Time	1.0	-	-	0.6	-	-	μs
t _{WR}	Write Cycle Time	-	-	5	-	-	5	ms

Notes: [1] This parameter is ensured by characterization not 100% tested

[2] AC measurement conditions:

- ✧ t_{AA} is the time (from the falling edge of SCL) required by the SDA bus line to reach either 0.3 VCC or 0.7 VCC, assuming that R_{bus} × C_{bus} time constant is within 400 ns for 0.4 MHz frequency, within 120 ns for 1 MHz frequency
- ✧ RL (connect to VCC): 1.3 kΩ
- ✧ CL = 100 pF
- ✧ Input pulse voltage: 0.2 VCC to 0.8 VCC
- ✧ Input rise and fall time: < 50 ns
- ✧ Input and output timing reference voltage: 0.3 VCC and 0.7 VCC

Table 3-5 High Speed Mode AC Characteristics ($T_A = -40\text{ }^\circ\text{C}$ to $+125\text{ }^\circ\text{C}$)

Symbol	Parameter	$1.7 \leq V_{CC} \leq 5.5$			Units
		Min.	Typ.	Max.	
f_{SCL}	Clock Frequency	-	-	3400	kHz
t_{LOW}	Clock Pulse Width Low	0.16	-	-	μs
t_{HIGH}	Clock Pulse Width High	0.11	-	-	μs
t_{AA}	Clock Low to Data Out Valid	0.01	-	0.14	μs
t_i	Noise Suppression Time	-	-	0.01	μs
t_{BUF}	Time the bus must be free before a new transmission can start	0.3	-	-	μs
$t_{HD.STA}$	Start Hold Time	0.16	-	-	μs
$t_{SU.STA}$	Start Setup Time	0.16	-	-	μs
$t_{HD.DAT}$	Data in Hold Time	0	-	-	μs
$t_{SU.DAT}$	Data in Setup Time	0.01	-	-	μs
t_R	Inputs Rise Time ^[1]	0.01	-	0.08	μs
t_F	Inputs Fall Time ^[1]	0.01	-	0.08	μs
$t_{SU.STO}$	Stop Setup Time	0.16	-	-	μs
t_{DH}	Data Out Hold Time	0.05	-	-	μs
$t_{SU.WCB}$	WCB pin Setup Time	0.6	-	-	μs
$t_{HD.WCB}$	WCB pin Hold Time	0.6	-	-	μs
t_{WR}	Write Cycle Time	-	-	5	ms

Notes: [3] AC measurement conditions:

- ◇ t_{AA} is the time (from the falling edge of SCL) required by the SDA bus line to reach either 0.3 VCC or 0.7 VCC, assuming that $R_{bus} \times C_{bus}$ time constant is within 20 ns
- ◇ RL (connect to VCC): 1.3 k Ω
- ◇ CL = 15 pF
- ◇ Input pulse voltage: 0.2 VCC to 0.8 VCC
- ◇ Input rise and fall time: < 50 ns
- ◇ Input and output timing reference voltage: 0.3 VCC and 0.7 VCC

Table 3-6 Reliability Characteristic ^[1]

Symbol	Parameter	Test condition	Min.	Unit
EDR ^[2]	Endurance	$T_A \leq 25\text{ }^\circ\text{C}$, $V_{CC}(\text{min}) < V_{CC} < V_{CC}(\text{max})$	10,000,000	Write cycles
		$T_A = 85\text{ }^\circ\text{C}$, $V_{CC}(\text{min}) < V_{CC} < V_{CC}(\text{max})$	4,000,000	
		$T_A = 125\text{ }^\circ\text{C}$, $V_{CC}(\text{min}) < V_{CC} < V_{CC}(\text{max})$	1,000,000	
DRET	Data retention	$T_A = 55\text{ }^\circ\text{C}$	200	Years
		$T_A = 85\text{ }^\circ\text{C}$	50	
		$T_A = 125\text{ }^\circ\text{C}$	20	

Note: [1] The Write cycle endurance is defined for groups of four data bytes located at addresses $[4*N, 4*N+1, 4*N+2, 4*N+3]$ where N is an integer, or for the status register byte. This parameter is ensured by characterization and is not 100% tested

[2] Under the condition: 3.3V, Page mode

Figure 3-1 Bus Timing

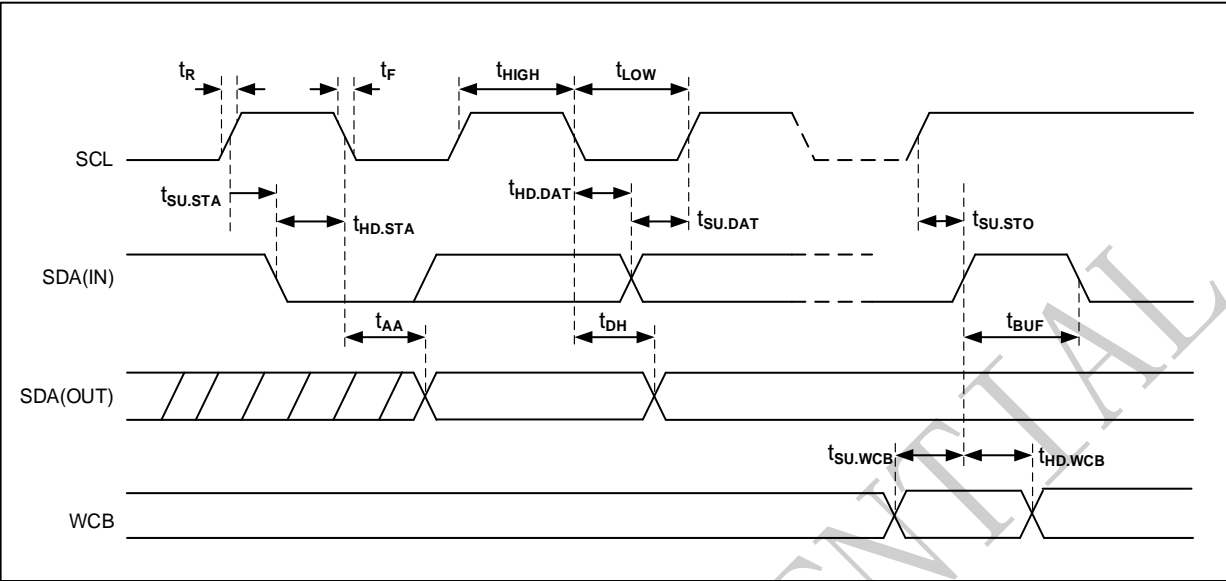
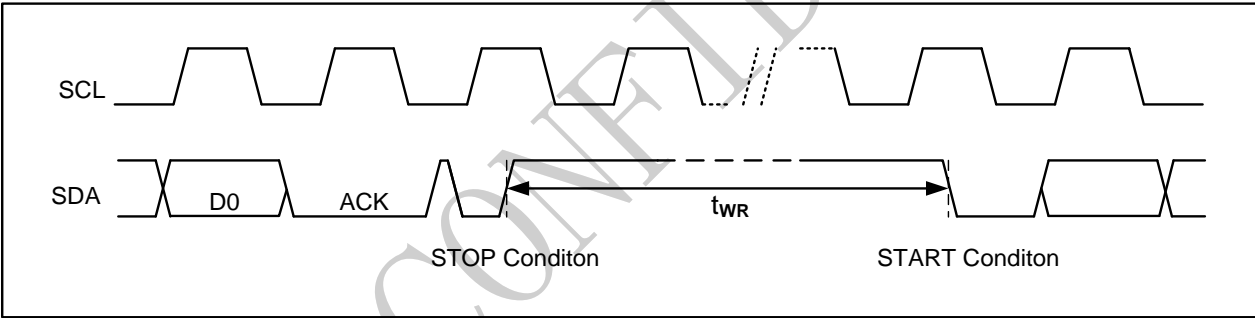

Figure 3-2 Write Cycle Timing



Note: [1] The write cycle time t_{WR} is the time from a valid stop condition of a write sequence to the end of the internal write cycle.

PUYA

Device Power-Up

The EEPROM has a built-in power-on-reset circuit that initializes itself at the same time during power-on. Unsuccessful initialization may cause a malfunction. To operate the power-on-reset circuit normally, the following conditions must be satisfied to raise the power supply voltage.

When initialization is successfully completed by the power-on-reset circuit, the EEPROM enters the standby status. t_{VSL} is the time required to initialize the EEPROM. No instructions are accepted during this time.

Figure 3-3 Power up Timing

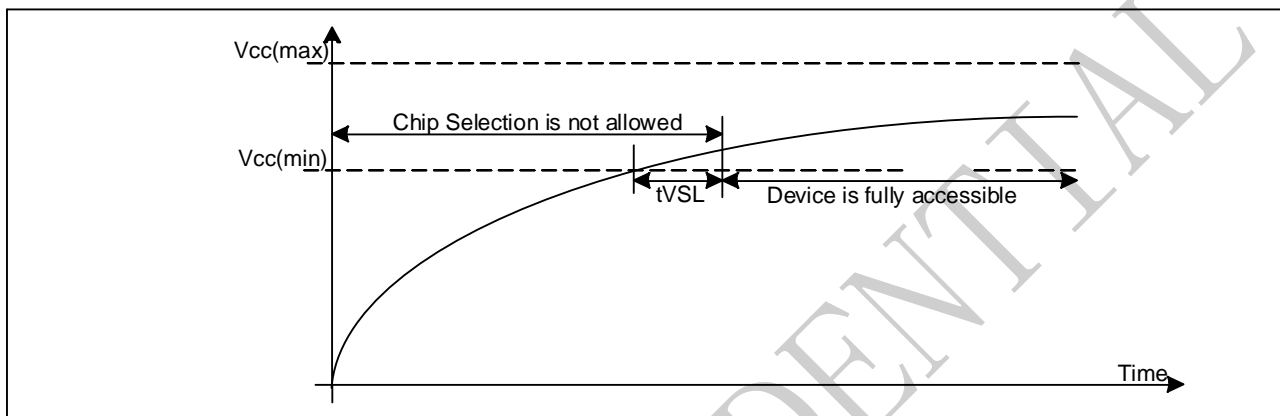

Power Up/Down and Voltage Drop

For Power-down to Power-up operation, the VCC of EEPROM device must be below VPWD for at least t_{PVD} timing. Please check the table below for more detail.

Figure 3-4 Power down-up Timing

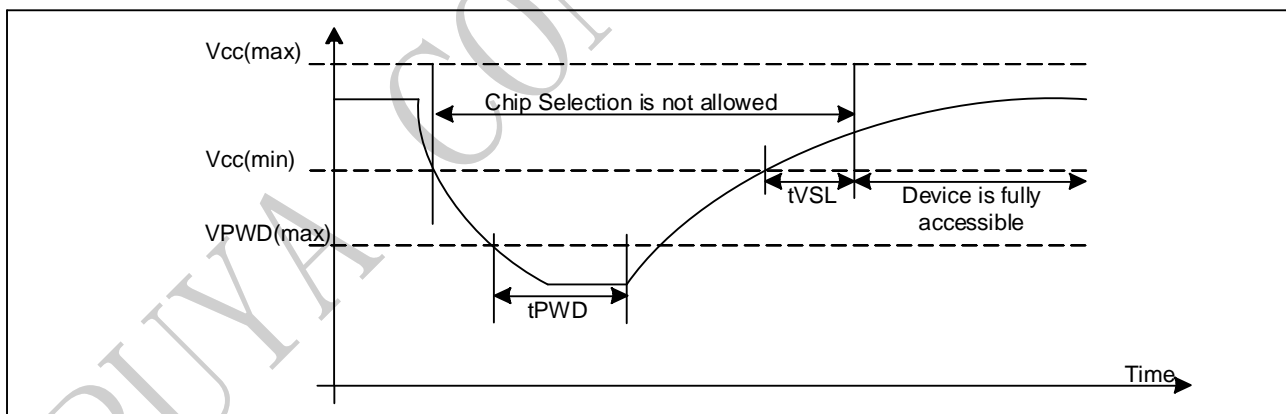

Symbol	Parameter	min	max	unit
VPWD	VCC voltage needed to below VPWD for ensuring initialization will occur		0.7	V
tPVD	The minimum duration for ensuring initialization will occur	300		us
tVSL	VCC(min.) to device operation	100		us
tVR	VCC Rise Time	1	500000	us/V

4. Device Operation

4.1 Data Input

The SDA pin is normally pulled high with an external device. Data on the SDA pin may change only during SCL low time periods (see to Figure 4-1). Data changes during SCL high periods will indicate a start or stop condition as defined in Figure 4-2.

Figure 4-1 Data Validity

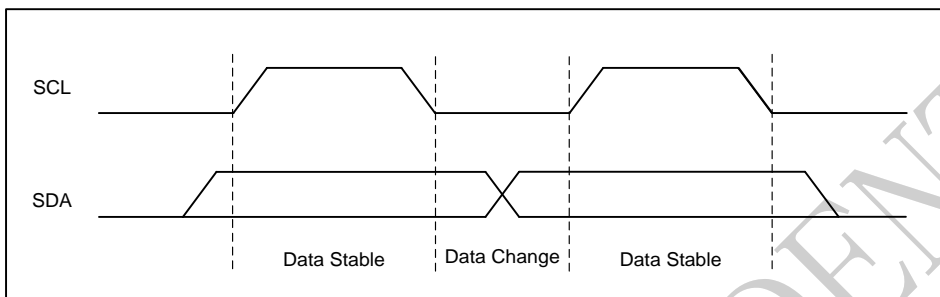

4.2 Start Condition

A high-to-low transition of SDA with SCL high is a start condition which must precede any other command (see to Figure 4-2).

4.3 Stop Condition

A low-to-high transition of SDA with SCL high is a stop condition. After a read sequence, the stop command will place the P24CM02H in a standby mode (see Figure 4-2).

Figure 4-2 Start and Stop Definition

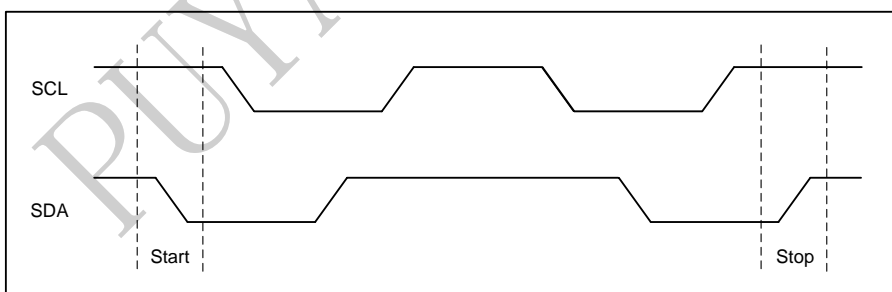

4.4 Acknowledge (ACK)

All addresses and data words are serially transmitted to and from the P24CM02H in 8-bit words. The P24CM02H sends a “0” to acknowledge that it has received each word. This happens during the ninth clock cycle.

Figure 4-3 Output Acknowledge

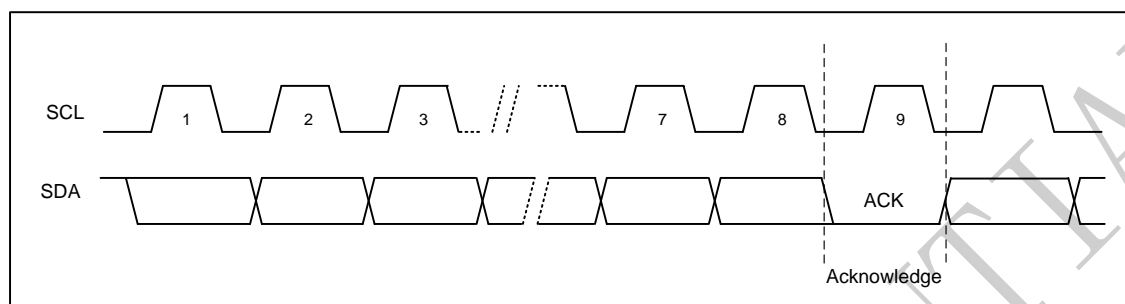

4.5 Power Up Sequence

During a power-up sequence, the V_{CC} supplied to P24CM02H should monotonically rise from GND to the minimum V_{CC} level as specified in Section 3, “Electrical Characteristics” with a slew rate no greater than 1V/us.

To prevent inadvertent write operations or other spurious events from happening during a power-up sequence, the P24CM02H includes a power-on-reset circuit. Upon power-up, the device will not respond to any commands until the V_{CC} level crosses the internal voltage threshold and waiting 100 μ s that brings the device out of reset and into standby mode.

4.6 Standby Mode

The P24CM02H features a low-power standby mode which is enabled: (a) after a fresh power up, (b) after receiving a STOP bit in read mode, and (c) after completing a self-time internal programming operation.

4.7 Soft Reset

After an interruption in protocol, power loss or system reset, any two-wire part can be reset by following these steps: (a) Create a start condition, (b) Clock nine cycles, and (c) create another start bit followed by stop bit condition, as shown below. The device is ready for the next communication after the above steps have been completed.

Figure 4-4 Soft Reset

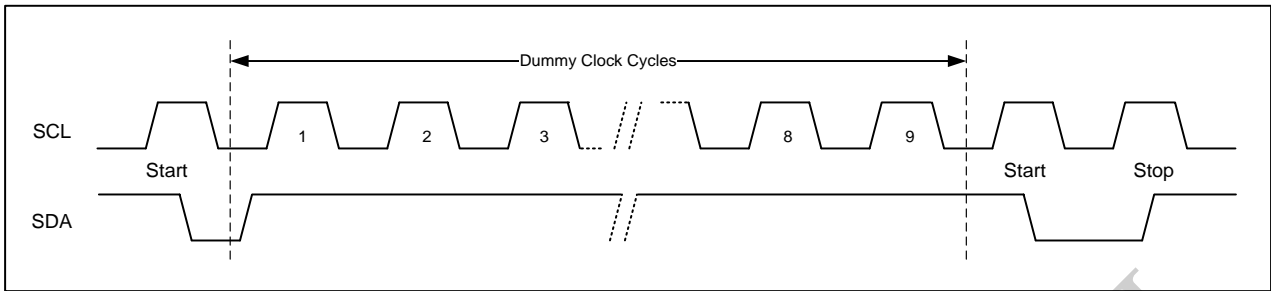

4.8 Device Addressing

The P24CM02H requires an 8-bit device address word following a start condition to enable the chip for a read or write operation (see Figure 4-5). The device address word consists of a mandatory one-zero sequence for the first four most-significant bits, as shown.

Figure 4-5 Device Address

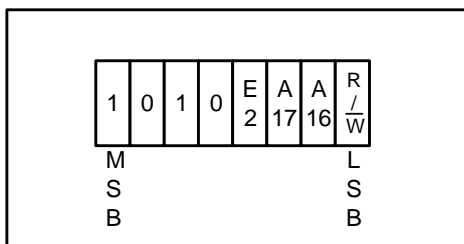

The E2 device address bit allows as many as two devices on the same bus. This bit must compare to its corresponding hardwired input pin.

The E2 pin uses an internal proprietary circuit that biases it to a logic low condition if the pin is floating.

The sixth (A17) and seventh bit (A16) of the device address are memory page address bits. These memory page address bits are the most significant bits of the data word address that follows.

The eighth bit of the device address is the read/write operation select bit. A read operation is initiated if this bit is high and a write operation is initiated if this bit is low. Upon a compare of the device address, the Chip will output a zero. If a compare is not made, the device will return to a standby state.

Table 4-1 Device Address

Chip	Access area	Bit 7	Bit 6	Bit 5	Bit 4	Bit 3	Bit 2	Bit 1	Bit 0
P24CM02H	Normal Area	1	0	1	0	E2	A17	A16	R/W
	ID Page	1	0	1	1	E2	X	X	R/W
	Lock Bit	1	0	1	1	E2	X	X	R/W
	Serial Number	1	0	1	1	E2	X	X	1

Table 4-2 Word Address0

Chip	Data	Bit 7	Bit 6	Bit 5	Bit 4	Bit 3	Bit 2	Bit 1	Bit 0
P24CM02H	Normal Area	A15	A14	A13	A12	A11	A10	A9	A8
	ID Page	X	X	X	X	0	0	X	X
	Lock Bit	X	X	X	X	X	1	X	X
	Serial Number	X	X	X	X	1	0	X	X

Table 4-3 Word Address1

Chip	Data	Bit 7	Bit 6	Bit 5	Bit 4	Bit 3	Bit 2	Bit 1	Bit 0
P24CM02H	Normal Area	A7	A6	A5	A4	A3	A2	A1	A0
	ID Page	A7	A6	A5	A4	A3	A2	A1	A0
	Lock Bit	X	X	X	X	X	X	X	X
	Serial Number	X	X	X	X	A3	A2	A1	A0

4.9 Data Security

P24CM02H has a hardware data protection scheme that allows the user to write protect the whole memory when the WCB pin is at Vcc.

4.10 ECC (Error Correction Code) and Write cycling

The Error Correction Code (ECC) is an internal logic function which is transparent for the I2C communication protocol.

The ECC logic is implemented on each group of four EEPROM bytes ^[1]. Inside a group, if a single bit out of the four bytes happens to be erroneous during a Read operation, the ECC detects this bit and replaces it with the correct value. The read reliability is therefore much improved.

Even if the ECC function is performed on groups of four bytes, a single byte can be written/cycled independently. In this case, the ECC function also writes/cycles the three other bytes located in the same group ^[1]. As a consequence, the maximum cycling budget is defined at group level and the cycling can be distributed over the 4 bytes of the group: the sum of the cycles seen by byte0, byte1, byte2 and byte3 of the same group must remain below the maximum value.

Note: [1] A group of four bytes is located at addresses $[4*N, 4*N+1, 4*N+2, 4*N+3]$, where N is an integer

4.11 High Speed Mode (HS-mode)

The P24CM02H supports 3.4 MHz high speed mode. A master code (00001XXXb) must be issued to place the device into high speed mode. Communication between master and slave will then be enabled for speeds up to 3.4 MHz. A STOP condition will exit Hs-mode. Single- and multiple-byte reads and writes are supported.

Figure 4-6 High Speed Mode Communication

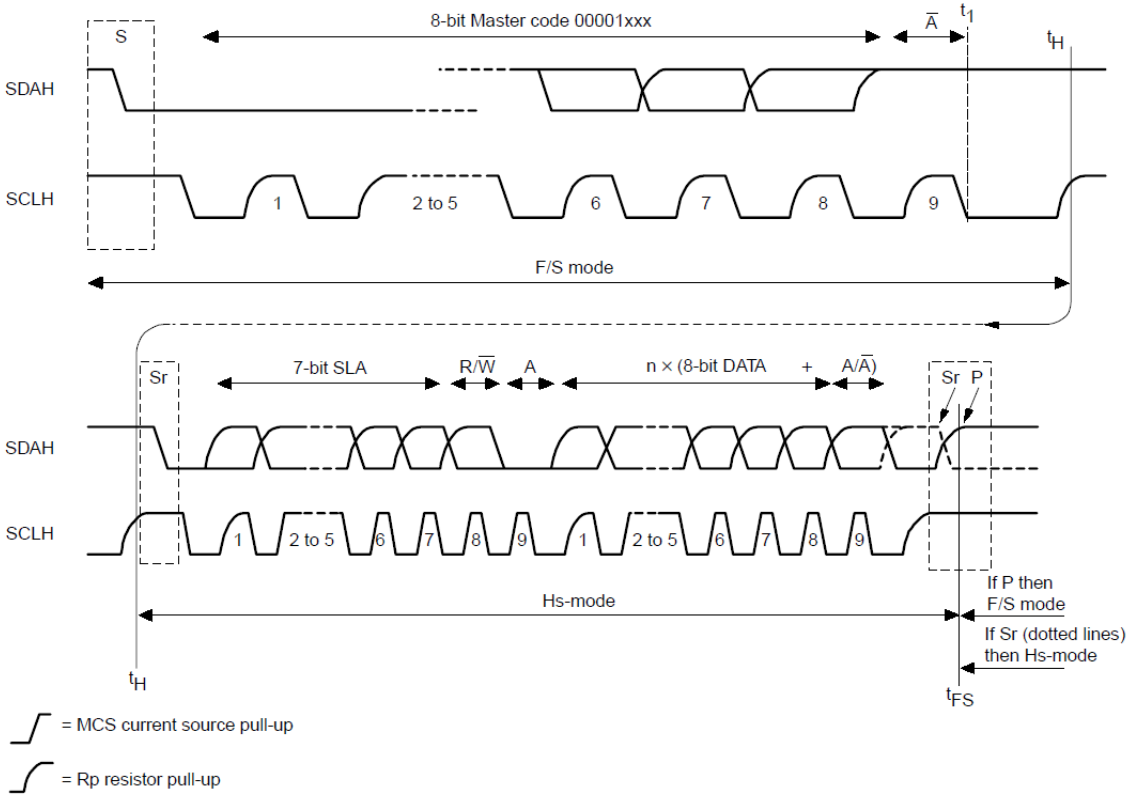

Sr: Repeated Start Flag



5. Instructions

5.1 Write Operations

5.1.1 Byte Write

A write operation requires 18-bit data word address following the device address word and acknowledgment. The word address field consists of the A17~A16 bit in the device address byte, then the most significant word address (A15~A8) followed by the least significant word address (A7~A0). Upon receipt of this address, the P24CM02H will again respond with a “0” and then clock in the first 8-bit data word. Following receipt of the 8-bit data word, the P24CM02H will output a “0” and the addressing device, such as a micro controller, must terminate the write sequence with a stop condition. And then the P24CM02H enters an internally timed write cycle, all inputs are disabled during this write cycle and the P24CM02H will not respond until the write is complete (see Figure 5-1).

Figure 5-1 Byte Write

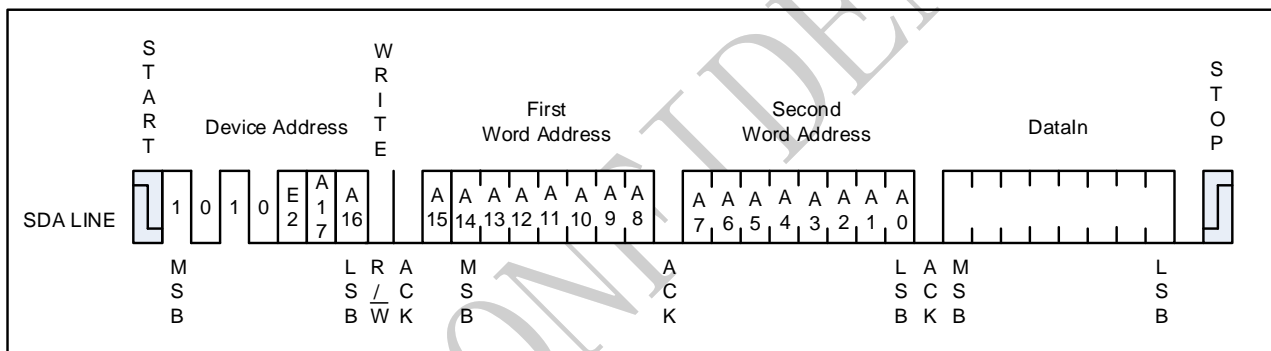

5.1.2 Page Write

A page write is initiated the same as a byte write, but the master does not send a stop condition after the first data word is clocked in. Instead, after the P24CM02H acknowledges receipt of the first data word, the master can transmit more data words. The P24CM02H will respond with a “0” after each data word received. The microcontroller must terminate the page write sequence with a stop condition.

Figure 5-2 Page Write

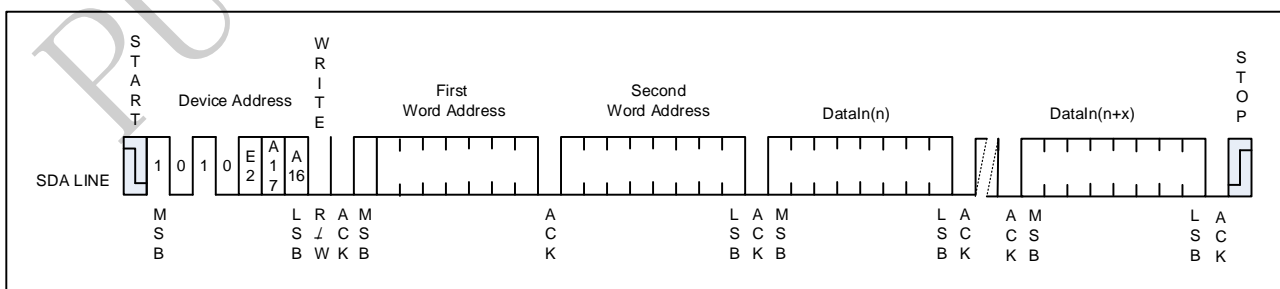

The lower eight bits of the data word address are internally incremented following the receipt of each data word. The higher data word address bits are not incremented, retaining the memory page row location. When the word address, internally generated, reaches the page boundary, the following byte is placed at the

beginning of the same page. If more than 256 data words are transmitted to the P24CM02H, the data word address will roll-over, and previous data will be overwritten. The address roll-over during write is from the last byte of the current page to the first byte of the same page.

5.1.3 Acknowledge Polling

Once the internally timed write cycle has started and the P24CM02H inputs are disabled, acknowledge polling can be initiated. This involves sending a start condition followed by the device address word. The read/write bit is representative of the operation desired. Only if the internal write cycle has completed will the P24CM02H respond with a “0”, allowing the read or write sequence to continue.

5.1.4 Write Identification Page

The Identification Page (256 bytes) is an additional page which can be written and later permanently locked in Read-only mode. It is written by the Write Identification Page instruction. This instruction uses the same protocol and format as Page Write, except for the following differences:

- Device type identifier = 1011b
- MSB address A11 and A10 must be “0” while other bits in A17~A8 are don't care.
- LSB address bits A7~A0 define the byte address inside the Identification page.

If the Identification page is locked, the data bytes transferred during the Write Identification Page instruction are not acknowledged (NoACK).

5.1.5 Lock Identification Page

The Lock Identification Page instruction (Lock Bit Write Instruction) permanently locks the Identification page in Read-only mode. The Lock ID Page instruction is similar to Byte Write with the following specific conditions:

- Device type identifier = 1011b
- Address bit A10 must be ‘1’; all other address bits are don't care
- The data byte must be equal to the binary value xxxx xx1x, where x is don't care

5.2 Read Operations

Read operations are initiated the same way as write operations with the exception that the read/write select bit in the device address word is set to “1”. There are three read operations: Current Address Read; Random Address Read and Sequential Read.

5.2.1 Current Address Read

The internal data word address counter maintains the last address accessed during the last read or write operation, incremented by one. This address stays valid between operations as long as the chip power is maintained. The address roll-over during read is from the last byte of the last memory page to the first byte of the first page.

Once the device address with the read/write select bit set to “1” is clocked in and acknowledged by the P24CM02H, the current address data word is serially clocked out. The microcontroller does not respond with

an input “0” but does generate a following stop condition (see Figure 5-3).

Figure 5-3 Current Address Read

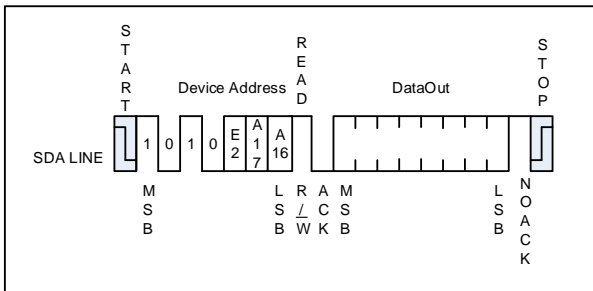

5.2.2 Random Read

A Random Read requires a “dummy” byte write sequence to load in the data word address. Once the device address word and data word address are clocked in and acknowledged by the P24CM02H, the microcontroller must generate another start condition. The microcontroller now initiates a Current Address Read by sending a device address with the read/write select bit high. The P24CM02H acknowledges the device address and serially clocks out the data word. The microcontroller responds with a “1” and generates stop condition (see Figure 5-4) followed.

Figure 5-4 Random Read

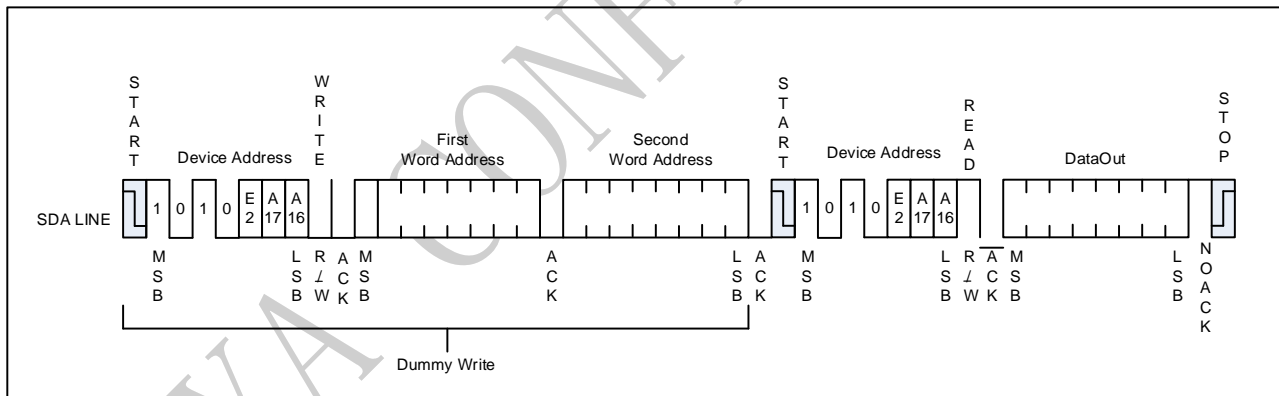

5.2.3 Sequential Read

Sequential Reads are initiated by either a Current Address Read or a Random Address Read. After the microcontroller receives a data word, it responds with acknowledge. As long as the P24CM02H receives acknowledge, it will continue to increment the data word address and serially clock out sequential data words. When the memory address limit is reached, the data word address will roll-over and the Sequential Read will continue. The Sequential Read operation is terminated when the microcontroller responds with a “1” and generates a stop condition (see Figure 5-5) followed.

Figure 5-5 Sequential Read

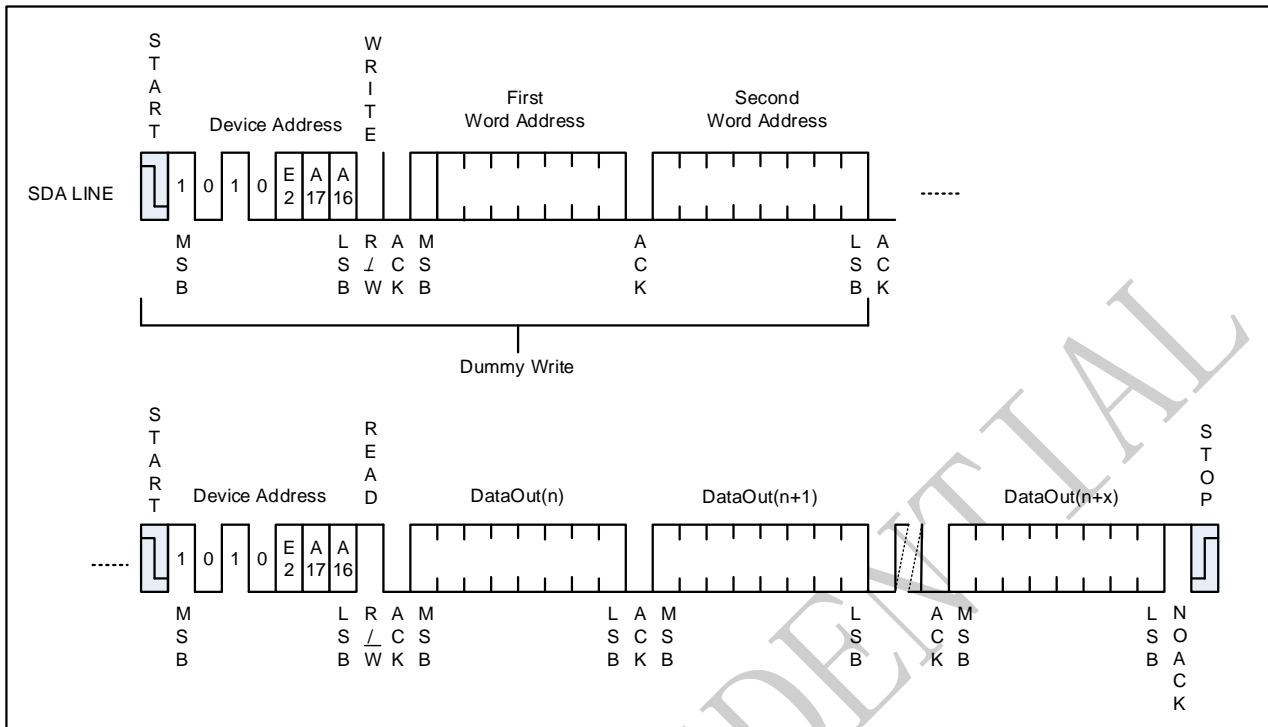

5.2.4 Read Identification Page

The Identification Page (256 bytes) is an additional page which can be written and later permanently locked in Read-only mode. The Identification Page can be read by Read Identification Page instruction which uses the same protocol and format as the Read Command with device type identifier defined as 1011b. The MSB address bits A17~A8 are don't care, the LSB address bits A7~A0 define the byte address inside the Identification Page. The number of bytes to read in the ID page must not exceed the page boundary (e.g. When reading the Identification Page from location 10d, the number of bytes should be less than or equal to 246, as the ID page boundary is 256 bytes).

5.2.5 Read Lock Status

The locked/unlocked status of the Identification page can be checked by transmitting a specific truncated command [Identification Page Write instruction + one data byte] to the device. The device returns an acknowledge bit if the Identification page is unlocked, otherwise a NO-ACK bit if the Identification page is locked.

Figure 5-6 Lock Status Read (When Identification page locked, return NO-ACK after one data byte)

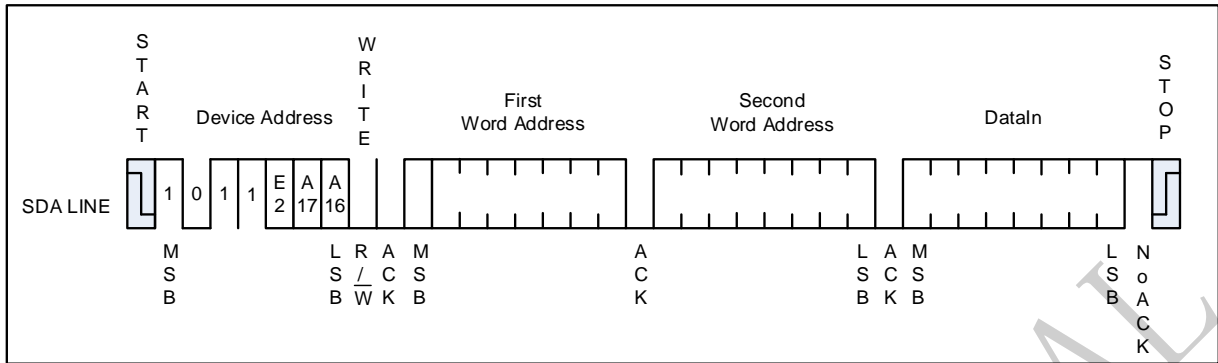

5.2.6 Read Serial Number

The Serial Number is only 16 bytes and is Read-only.

Reading the Serial Number is similar to the sequential read sequence but requires use of the device address. Refer to Table 4-1, the device type identifier should be 1011B. The word address A11~A10 must be 10B, A3~A0 must define the byte address inside the Serial Number. It is recommended A3~A0 be 0 and the read data number must be 16 to guarantee the entire 128 bits value correctly read out.

Example: If the application desires to read the first byte of the serial number, the word address input would need to be 0800h.

The Serial Number Read operation is terminated when the master does not respond with a zero (ACK) and instead issues a STOP bit (Refer to Figure 5-7)

Figure 5-7 Serial Number Read

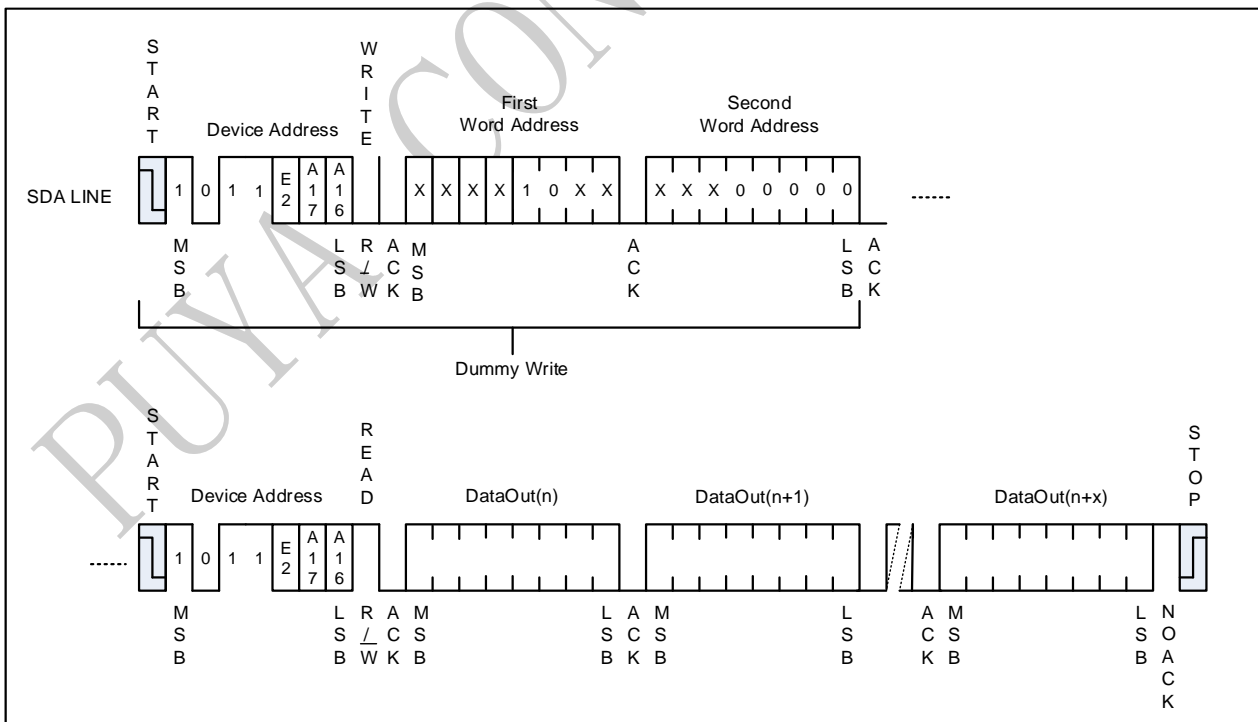

Notes: [1] x means don't care bits.

6. Ordering Code Detail

Example:

P 2 4 C M02 H – SS H – M I R

Company Designator

P = Puya Semiconductor

Product Series Name

24C = I2C-compatible Interface EEPROM

Device Density

M02 =2M bits

Device Reversion

H = Version H

Package Option

DP: PDIP8

SS: SOP8

TS: TSSOP8

UN: UDFN8

WF: WAFER

MS: MSOP8

ST: SOT23-5

TO: TSOT23-5

Plating Technology

H: RoHS Compliant, Halogen-free

Operation Voltage

M: 1.7~5.5V

Device Grade

I: -40~85C

K: -40~105C

E: -40~125C

Shipping Carrier Option

W: WAFER

T: TUBE

R: TAPE& REEL

7. Package information

7.1 PDIP8

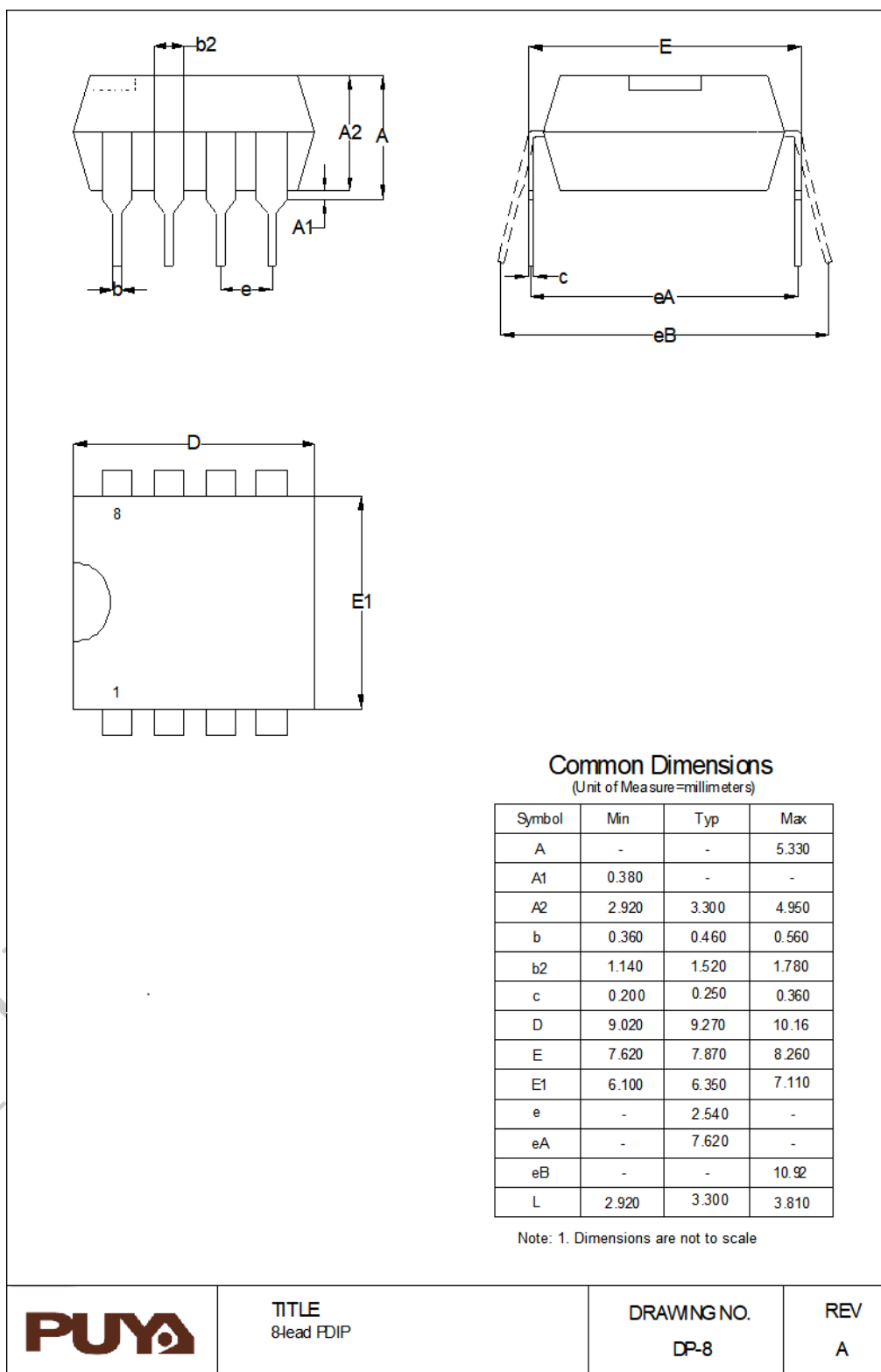

7.2 SOP8

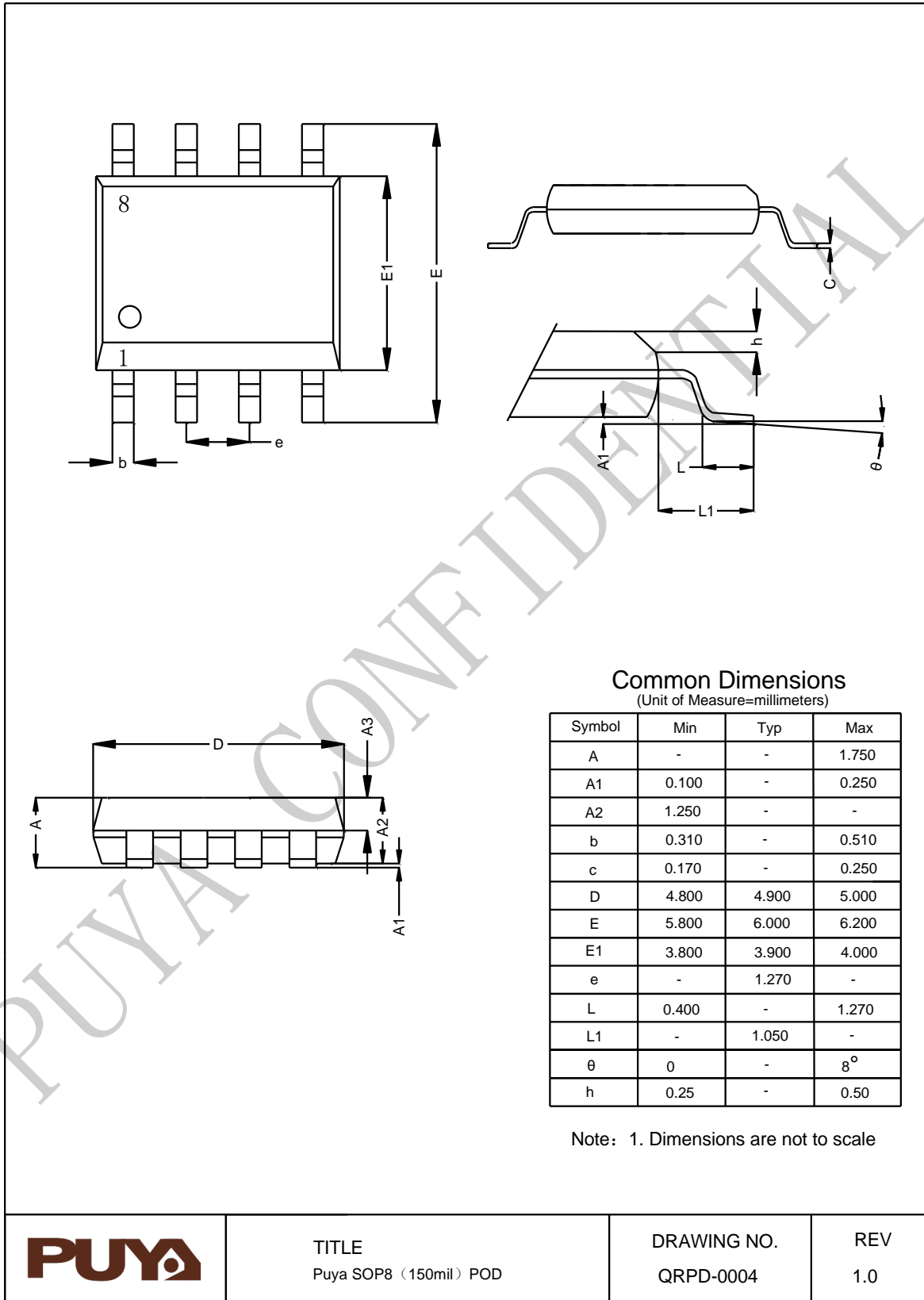

7.3 TSSOP8

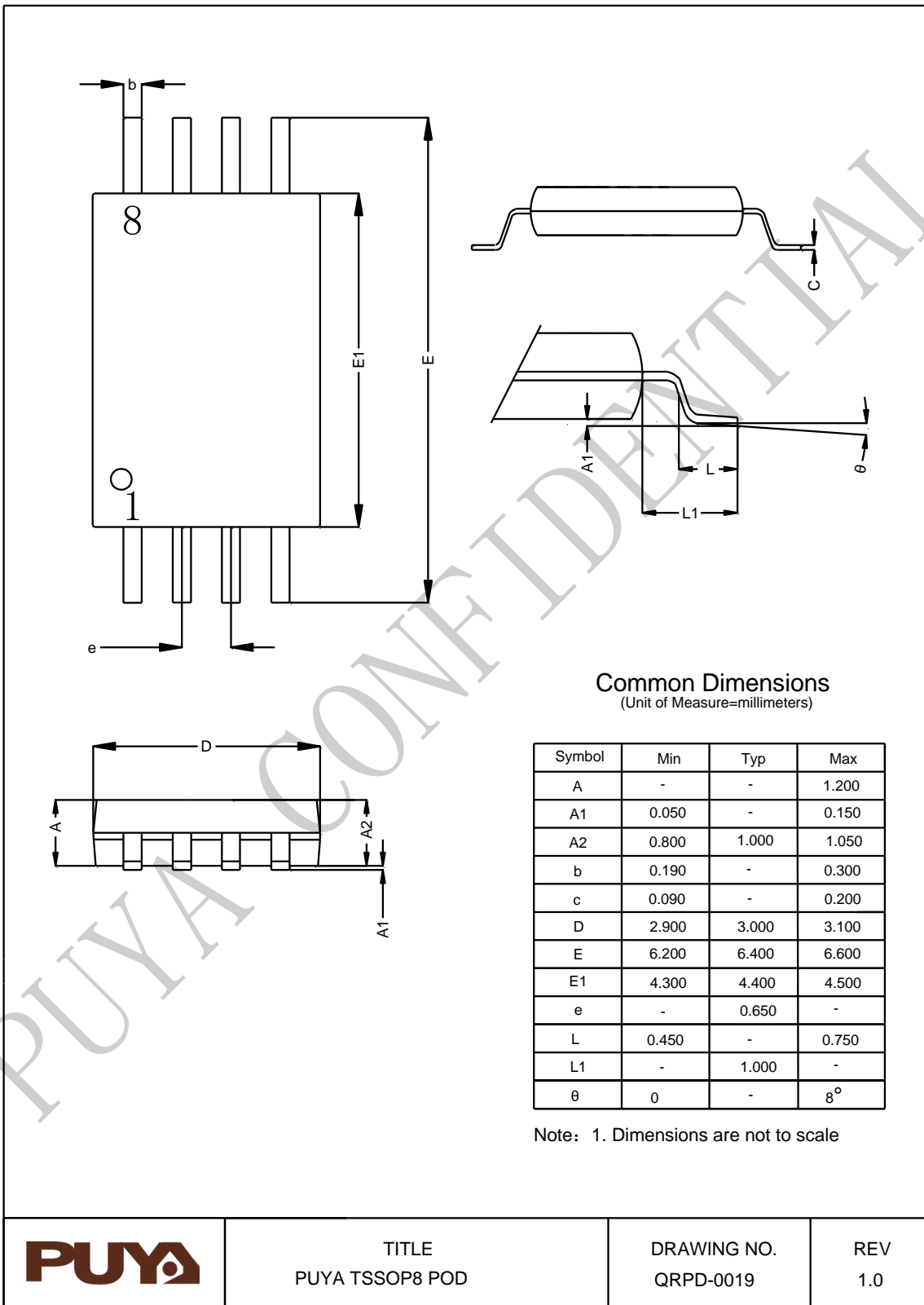

TITLE
PUYA TSSOP8 POD

DRAWING NO.
QRPD-0019

REV
1.0

7.4 UDFN8 (UN)

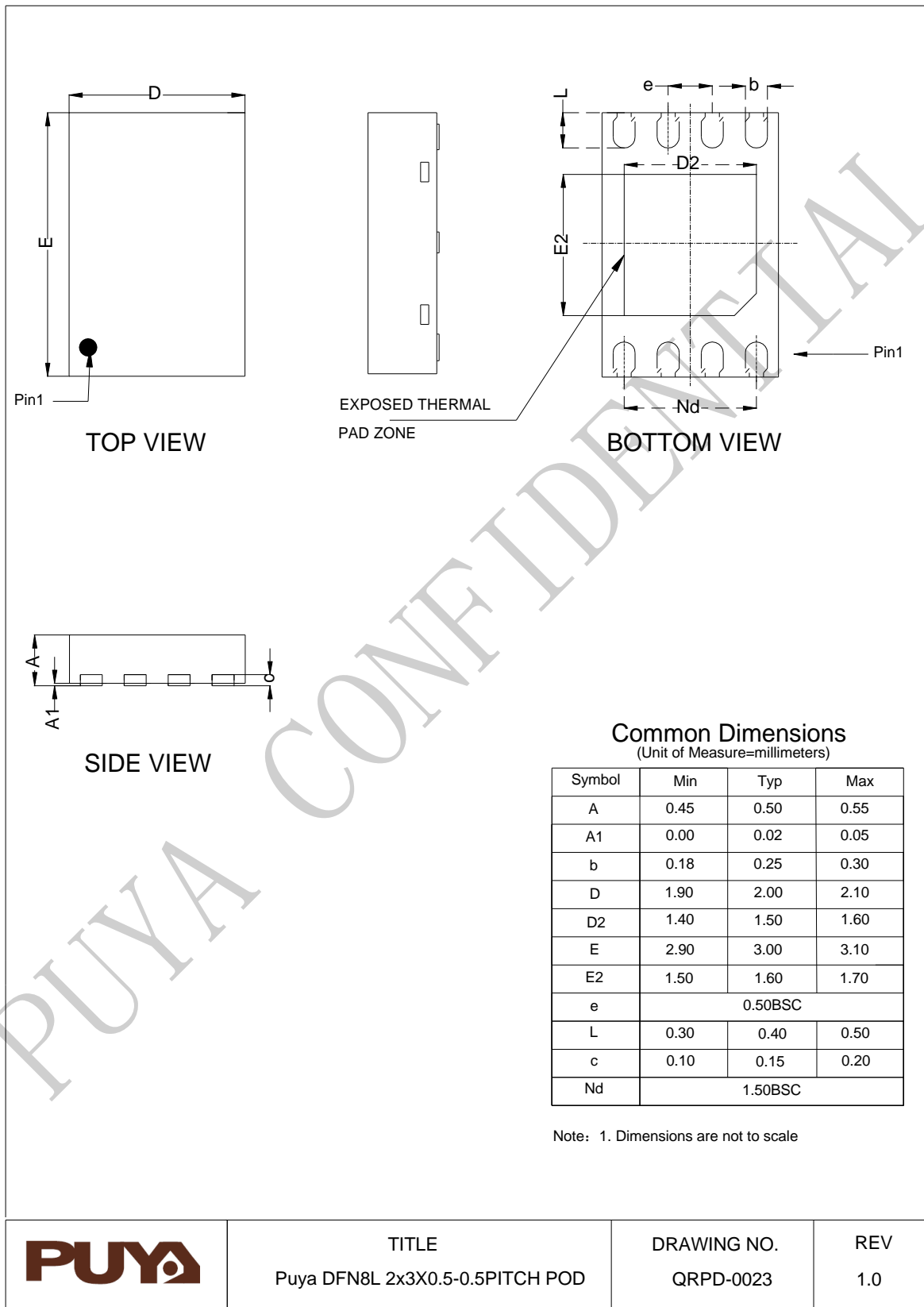

7.5 MSOP8

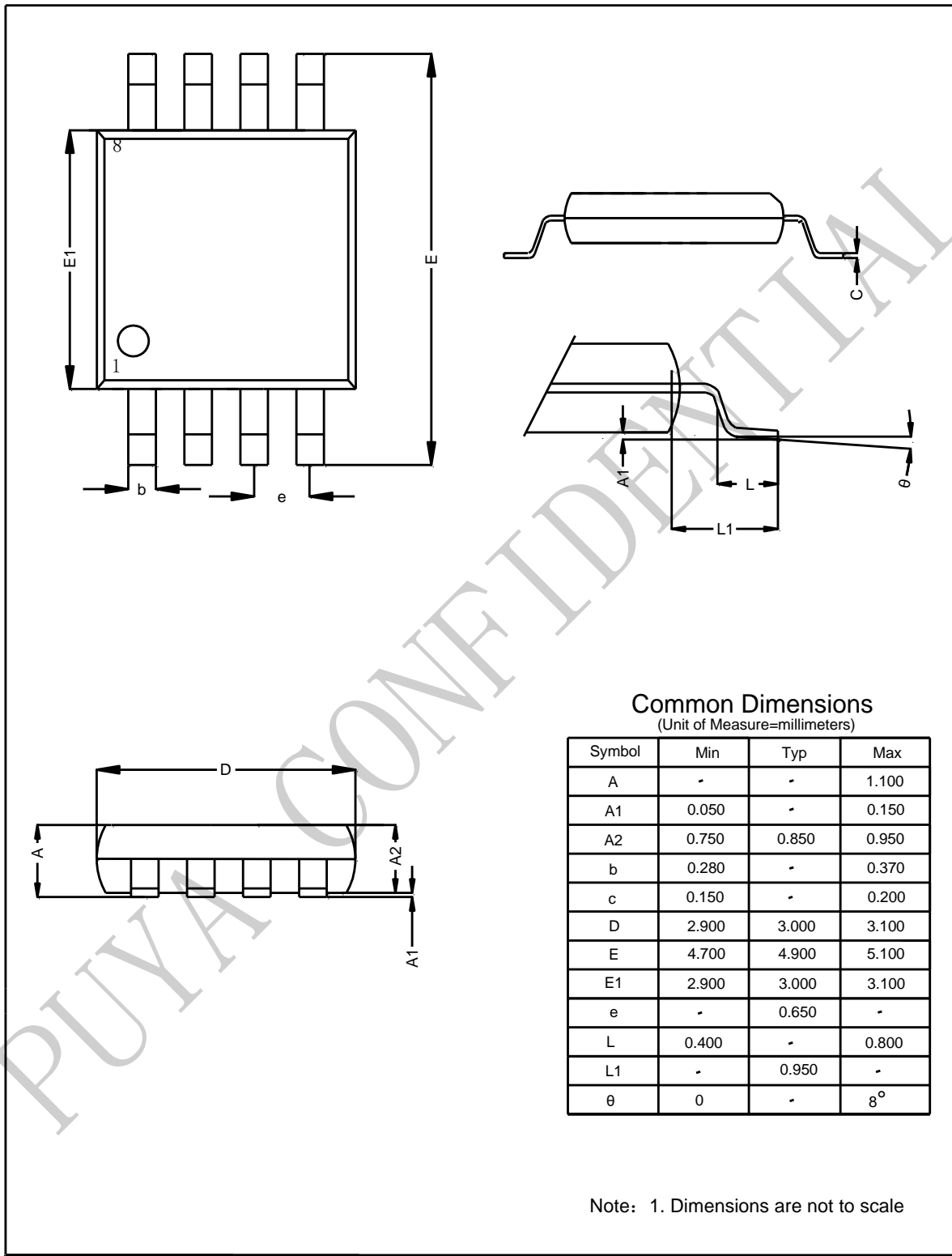

Common Dimensions
(Unit of Measure=millimeters)

Symbol	Min	Typ	Max
A	-	-	1.100
A1	0.050	-	0.150
A2	0.750	0.850	0.950
b	0.280	-	0.370
c	0.150	-	0.200
D	2.900	3.000	3.100
E	4.700	4.900	5.100
E1	2.900	3.000	3.100
e	-	0.650	-
L	0.400	-	0.800
L1	-	0.950	-
theta	0	-	8°

Note: 1. Dimensions are not to scale

	TITLE	DRAWING NO.	REV
	Puya MSOP8 POD	QRPD-0020	1.0

7.6 SOT23-5

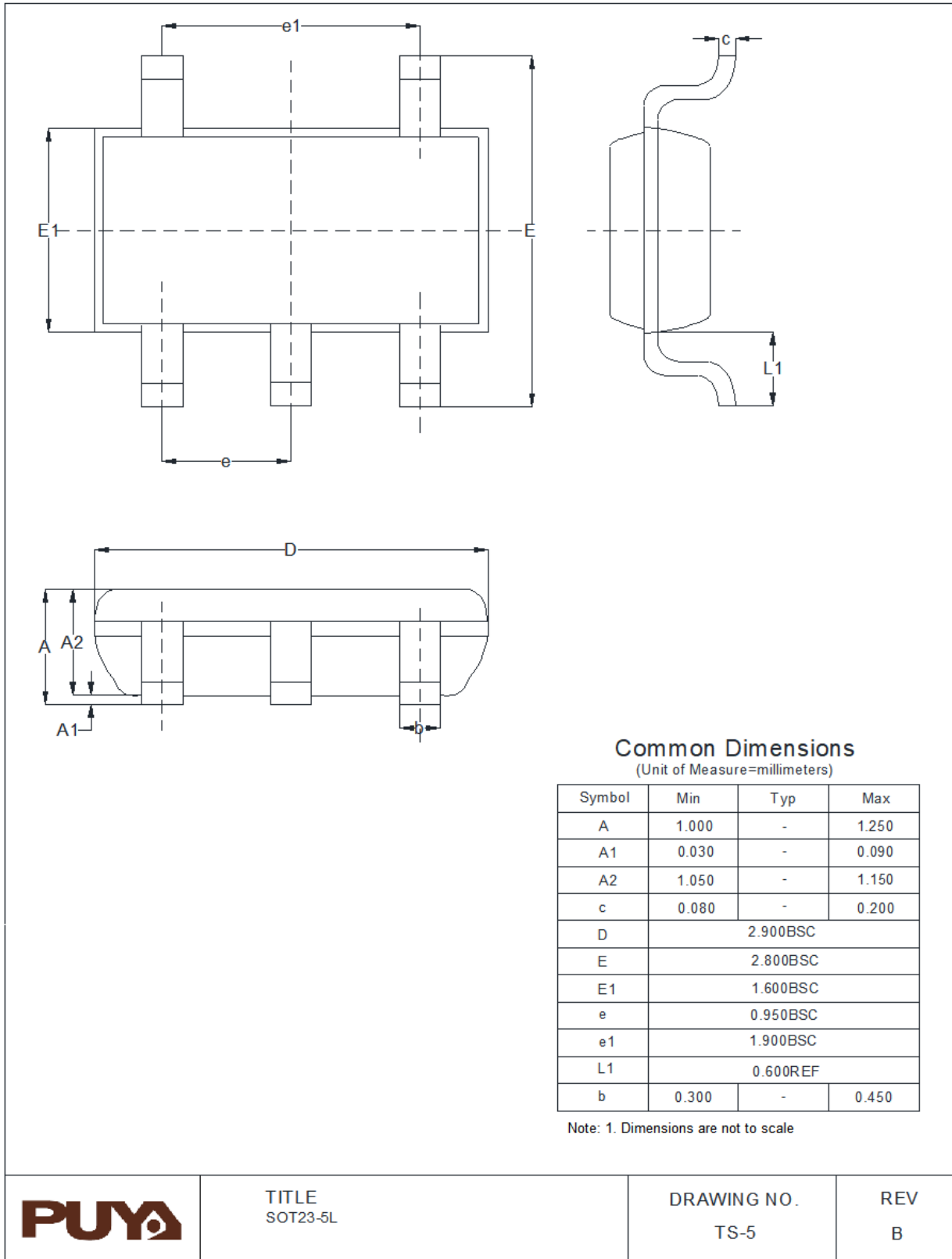

7.7 TSOT23-5

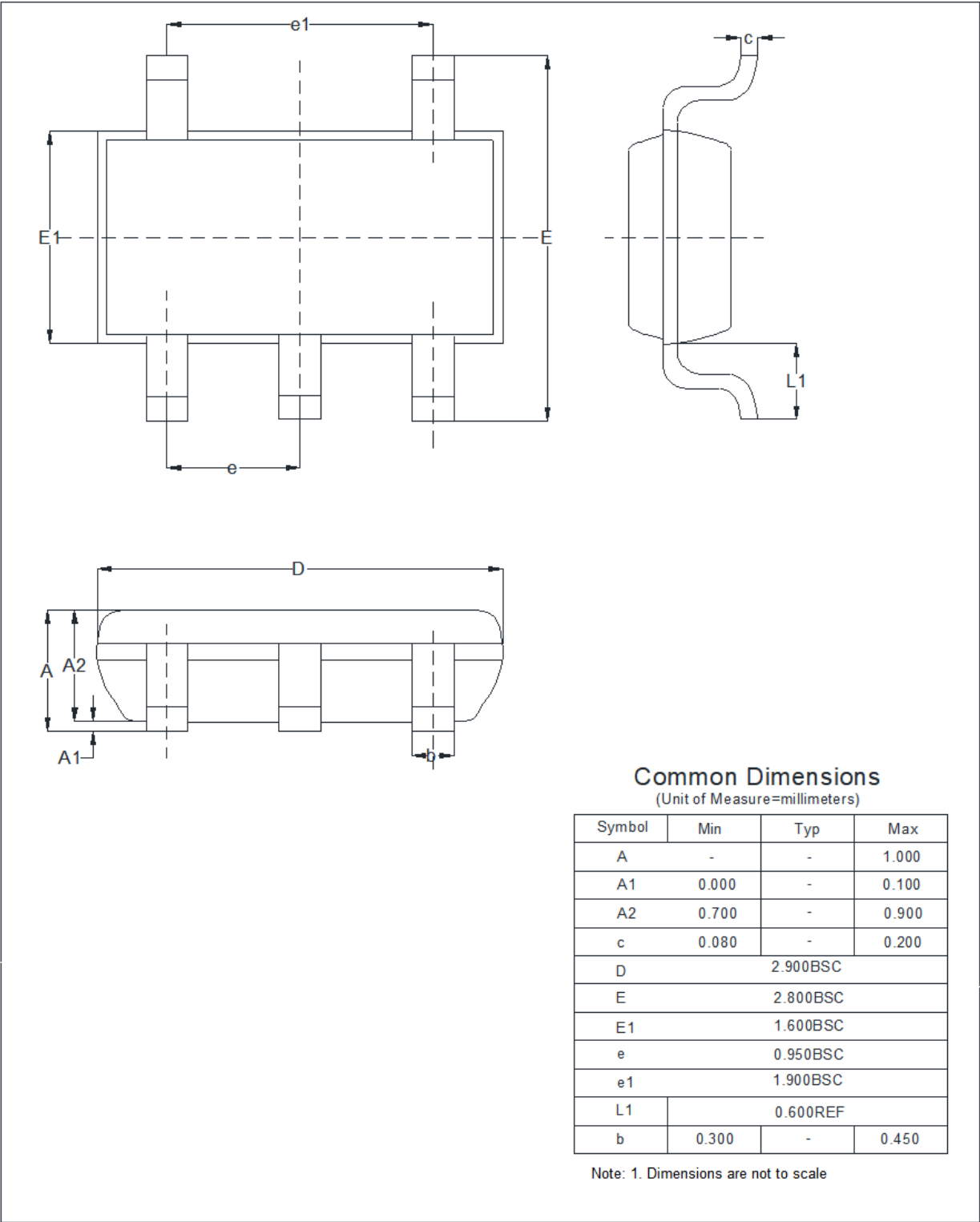

	TITLE TSOT23-5L	DRAWING NO. TS-5	REV B
---	--------------------	---------------------	----------

8. Revision History

Version	Content	Date
Rev 0.5	Initial Release	2024-09-05



Puya Semiconductor Co., Ltd.

IMPORTANT NOTICE

Puya Semiconductor reserves the right to make changes without further notice to any products or specifications herein. Puya Semiconductor does not assume any responsibility for use of any its products for any particular purpose, nor does Puya Semiconductor assume any liability arising out of the application or use of any its products or circuits. Puya Semiconductor does not convey any license under its patent rights or other rights nor the rights of others.